

HVA45 - _

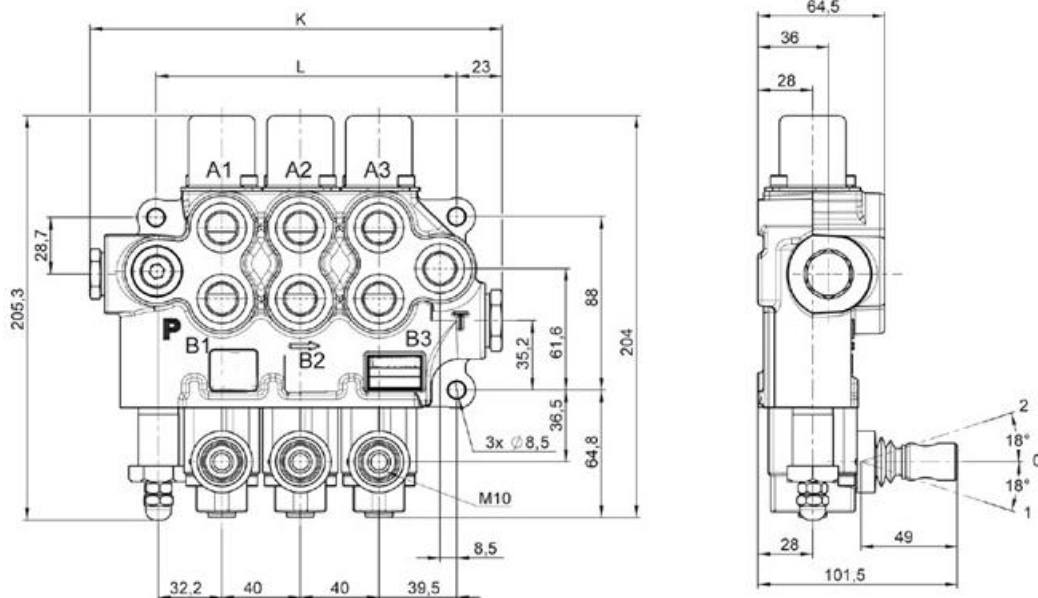

➤ TECHNISCHE DATEN

Artikelnummer	L (mm)	K (mm)	Gewicht
HVA45-1	73	129,5	3,60 Kg
HVA45-2	113	169,5	5,50 Kg
HVA45-3	153	209,5	7,40 Kg
HVA45-4	193	249,5	9,45 Kg
HVA45-5	233	289,5	11,25 Kg
HVA45-6	273	329,5	13,20 Kg

➤ STANDARD GEWINDE

Code	P	A/B	T	T1
A	G 3/8	G 3/8	G 3/8	G 1/2
B	G 1/2	G 1/2	G 1/2	G 1/2